

CSR PROJECT REPORT

Project Title - Improving Water, Sanitation and Hygiene (WaSH) for Tea Worker Communities in Assam

Duration – Six Months (1st October 2023 to 31st March 2024)

Project Location – Meleng Tea Estate, Jorhat district, Assam

Budget – Rs. 17,38,750.00 (Rupees Seventeen Lac Thirty Eight Thousand Seven Hundred Fifty).

Name of Implementing Organisation – North-East Affected Area Development Society (NEADS)

Project Background

Assam, located in northeastern India is known for its tea industry, which employs a substantial portion of the population. However, tea worker communities in the estate face significant challenges due to inadequate facilities for Water, Sanitation and Hygiene (WaSH) at household level as well as at their workplaces, creches and other public places. Poor access to clean water sources, inadequate sanitation facilities and a lack of awareness about hygiene practices contribute to health problems, including waterborne diseases and this has also connections with malnutrition and reproductive health of women.

Water and sanitation-related diseases continue to remain among the major causes of death among children under five years of age. In India, the under-five mortality rate is 50 per thousand live births as compared to the global average of 41. The lack of sanitation facilities leads to groundwater contamination and pathogen contamination leads to diarrhoeal diseases, resulting in malnutrition, stunting, and death. Women, who do not have access to toilets, mostly relieve themselves under the cover of darkness, i.e., before dawn or after sunset. Such practices are not only a threat to their physical security but are also a cause of various diseases.

This project aims to address these challenges by improving WaSH infrastructure and promoting public health practices among the tea worker communities in Assam. This project will focus on Meleng Tea Estate where NEADS has presence through other project activities.

Project Location

The project will be implemented in **Meleng Tea Estate** in Jorhat, Assam.

Target Beneficiaries

The project will focus on benefiting approximately 500 tea workers and their families in Meleng Tea Estate, Jorhat, Assam for hygiene and water related interventions and for household toilets, NEADS will focus on 30 households who do not have toilets and go for open defecations. These communities often lack access to basic WaSH facilities and face health challenges due to these shortcomings.

Project Objectives

Sl. No.	Project Objectives under Schedule VII of Company's Act 2013	Primary Project Objectives	Project Activities
1	Eradicating hunger, poverty and malnutrition, promoting health care including preventive health care and sanitation including contribution to the Swach Bharat Kosh set-up by the Central Government for the promotion of sanitation and making available safe drinking water.	<ul style="list-style-type: none"> • To improve water quality at source and point of use and to give access to safe sanitation facilities for 30 households and community in general in Meleng tea estate. • To promote hygiene and public health awareness amongst communities targeting children, youth and adults to reduce water, sanitation and hygiene related diseases and improve health condition of the communities 	<ul style="list-style-type: none"> • Construction of 30 new sanitation facilities relevant for the local context. • Hygiene awareness workshops for community members • Campaign on Public Health Promotion through community ownership • Develop and disseminate culturally relevant communication materials (posters, leaflets etc.) to promote positive WASH behaviours targeting tea workers and the communities (500 persons) • Train community members in routine maintenance and minor repairs of drinking water sources with support on disinfection of water sources
2	Promoting education, including special education and employment enhancing vocation skills especially among	Through improving the ICDS centre/creche facility in the gardens will	Renovation of one functional Anganwadi (ICDS) Centre or estate

	children, women, elderly and the differently abled and livelihood enhancement projects	help improving safe and hygienic creche facilities for children and will give access to good teaching and learning materials for overall development of the children.	creche after conducting a baseline study on the needs and communities' priorities.
3	Promoting gender equality, empowering women, setting up homes and hostels for women and orphans; setting up old age homes, day care centres and such other facilities for senior citizens and measures for reducing inequalities faced by socially and economically backward groups.	<ul style="list-style-type: none"> • To enhance the overall well-being and quality of life for the target communities • To promote gender equality and improve the dignity of women by constructing household based new sanitation facilities who otherwise go for open defecation • To promote gender equality and empower women by supporting them with routine check-up during pregnancy and also post-natal care in Anganwadi centre. 	<ul style="list-style-type: none"> • Training and empower community health workers. <p><i>Note: Construction of new 30 sanitation facilities and renovation of Anganwadi Centre or the estate creche would also meet this project objective</i></p>

Project Activities

To achieve the project objectives, NEADS will undertake the following activities:

➤ **Construction of new sanitation facilities (latrines) – 30 households**

Most of the families do not have their individual household toilets as most old toilets are defunct now even within two to three years of the construction. The families who received toilets under government scheme (Swacch Bharat Mission) are also unable to use them for longer time. This is due to poor quality of toilet construction which get defunct within short span of time. Though there has been the construction of individual toilets at the household level, it has been found

that more than 50% of the households 'toilets have not been completed. Therefore, it is proposed to construct 30 units of new sanitation facilities in the target area in order to promote safe sanitation and reduce the percentage of open defecation.

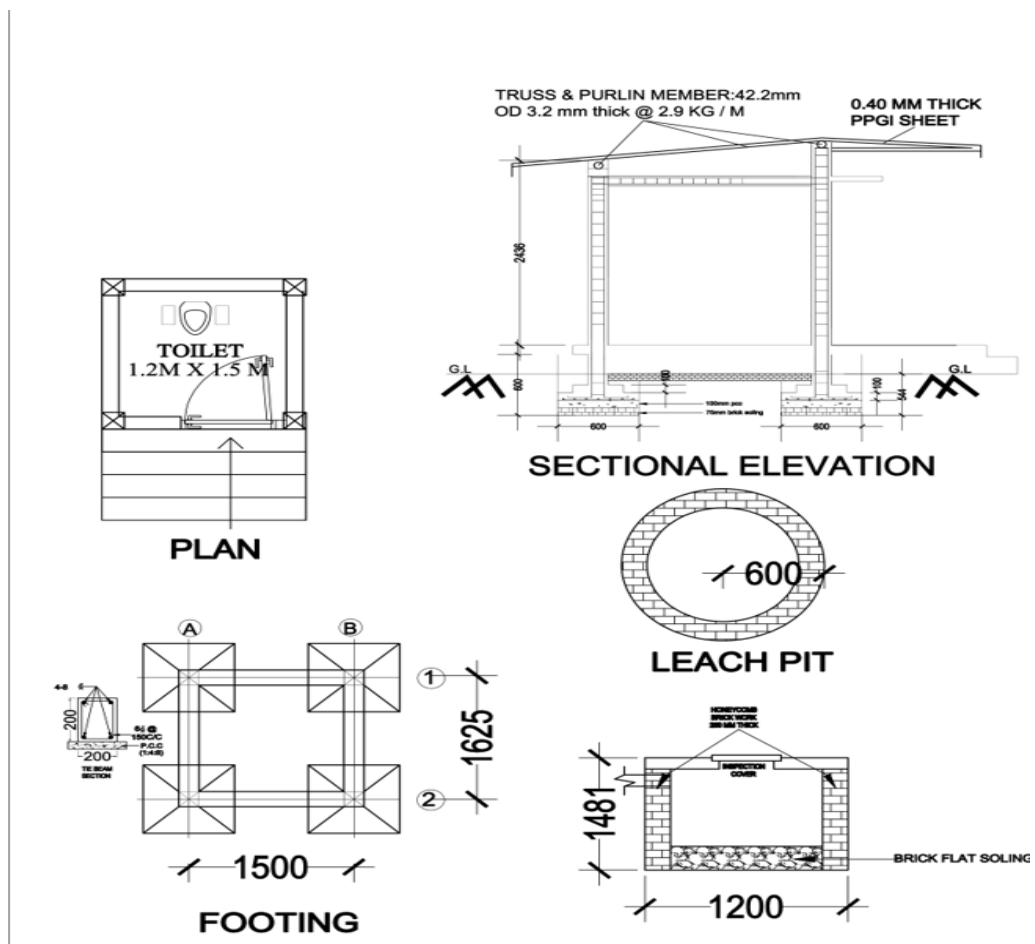

➤ **Renovation & supporting of Anganwadi Centre/Estate Creche – 1 number.**

In fulfilment of the ICDS Scheme, Anganwadi Centres are created to provide supplementary nutrition and growth monitoring, immunization, health check-up, health referral services, non-formal pre-school education and health and nutrition education. Most of these Anganwadi centers in the target villages are still not equipped with adequate infrastructures, functional equipment, tools and medicines. Furthermore, Anganwadi workers and assistance are not fully aware of the norms regarding nutrition and other key services to be provided under the scheme. There are a few creches built by the estate as well – the creches which are on use and functional, but with limited facilities will be targeted for the renovation/support work.

A thorough baseline assessment and community consultation will be done to prioritize the creche or the ICDS (Anganwadi Centre) for renovation work and to provide additional

support. The project is planning to upgrade 1 centre with joyful learning amenities & Bala painting along with proper infrastructure with toilet and sanitation facilities.

➤ **Train community members in routine maintenance and minor repairs of drinking water sources with support on disinfection of water sources**

For maintaining a healthy life, it is of utmost importance to have a safe water source for every family. But it is often seen specially in remote/under-developed areas, that the water sources are contaminated and not well-maintained by the people. This leads to water contamination resulting in health issues of the family. In order to address this issue, it is proposed to train a group of community members in routine maintenance and minor repairs of drinking water sources. The members will also be trained on chlorination of the water sources providing a kit for chlorination as well.

➤ **Develop and disseminate culturally relevant communication materials (posters, leaflets etc.) to promote positive WASH behaviours.**

Communication materials help people to understand better and get exact message conveyed to them. Therefore, while promoting public health and WaSH, it is planned to develop and disseminate the relevant communication materials such as handwashing practices, safe sanitation practices, safe drinking water, etc in the form of posters and leaflets.

➤ **Hygiene awareness workshops for community members**

In order to promote hygiene and public health, it is planned to train the community members on menstrual hygiene, household hygiene practices, clean drinking water and safe sanitation. This activity will primarily focus on women, who are mainly indulged in household chores and taking care of family member often forgetting their own health. This leads to several water-borne and skin related diseases. Therefore, the women section of the area will be targeted in maintaining a healthy life and clean environment.

➤ **Training and empower community health workers.**

The importance of a community health worker is well known for enhancement of overall well-being and improved quality of life of an individual. But in remote and underdeveloped areas, these health workers lack upgraded and adequate training which as a result cannot meet the health disparities in the area. Therefore, it is proposed to train and empower the health workers with creative strategies, materials and tools for training, educating and changing lifestyle behaviours so that they can be active promoters of health in their community.

➤ **Campaign on Public Health Promotion through community ownership - clean household, clean surrounding and environmental hygiene (waste free environment) in lines**

It is planned to organize hygiene promotion by villagers to ensure that the community is engaged in keeping the village clean. The clean drive/campaign will be initiated involving the community to clean public toilets, water points, school, Anganwadi centres, approach roads, drainage systems, waste management disposal, etc. WaSH promoter along with staff will lead and guide the community level hygiene promotion. Subsequently, WaSH Mela will also be held in public place to showcase WaSH models, structures, mechanisms etc prepared by women groups, students, youth groups.

Expected Outcomes

The project aims to achieve the following outcomes:

- Enhanced sanitation facilities in 30 households and also in the community.
- Increased awareness and adoption of hygiene practices, reducing the incidence of waterborne diseases – reaching out 500 individuals or more.
- Improved overall health and well-being of the target beneficiaries.
- Upgraded 1 Anganwadi/ICDS or Estate creche with joyful learning amenities & Bala painting along with proper infrastructure with toilet and sanitation facilities.

Budget

The project budget is estimated at INR 17,38,750.00 (Rupees Seventeen Lakhs, thirty-eight thousand, seven hundred and fifty only), including construction costs, training, awareness campaigns, and operational expenses. Detailed financial breakdowns are available in the budget.

Monitoring and Evaluation

A robust monitoring and evaluation system will be established to track project progress and outcomes. Regular assessments and surveys will measure the impact on WaSH facilities and public health indicators.

Sustainability

To ensure the sustainability of the project, we will:

- Engage local communities in project planning and implementation.
- Train community members to manage and maintain WaSH infrastructure.
- Facilitate knowledge transfer and capacity building for long-term self-reliance.

Project Timeline

The project will be implemented over 6 months, with the following key milestones:

- Months 1: Project initiation and community mobilization.
- Months 2-5: Construction of WaSH infrastructure and hygiene promotion activities.
- Months 6: Monitoring, evaluation and sustainability planning.

Conclusion

This project proposal aims to address the critical issues of water, sanitation and hygiene for marginalized tea worker communities in the targeted tea estate. By improving WASH facilities and promoting public health practices, we can enhance the quality of life and well-being of these communities.